

H. A. REED & W. H. MADDOCK.  
MACHINE FOR TURNING CRANK PINS.

No. 322,320.

Patented July 14, 1885.

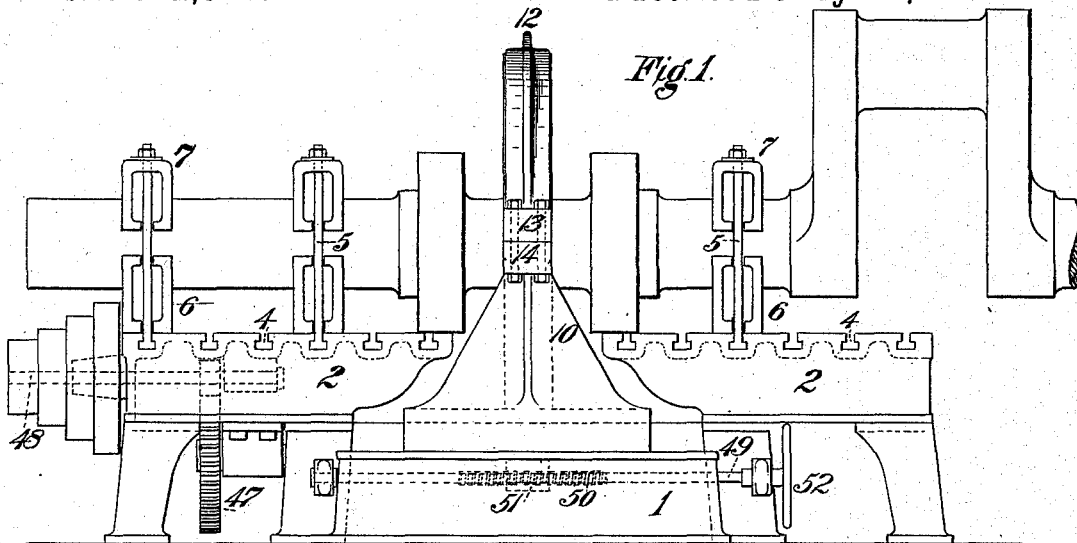

Fig. 1.

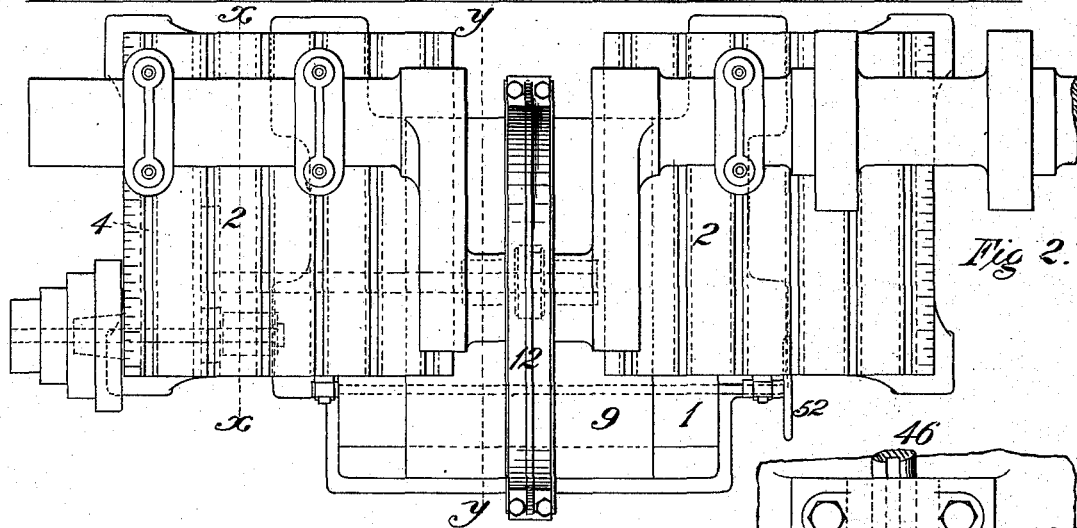

Fig. 2.

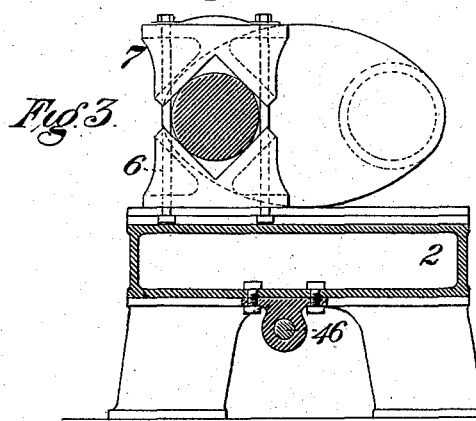

Fig. 3.

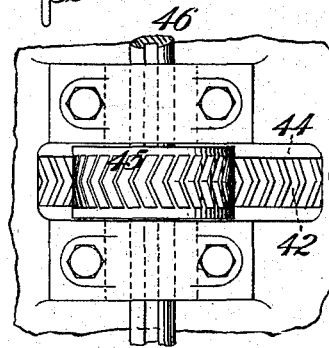

Fig. 4.

WITNESSES:  
Samuel S. Walcott  
O. M. Clarke

INVENTORS:  
Hugh A. Reed  
William H. Maddock  
BY George H. Christy  
ATTORNEY.

H. A. REED & W. H. MADDOCK.  
MACHINE FOR TURNING CRANK PINS.

No. 322,320.

Patented July 14, 1885.

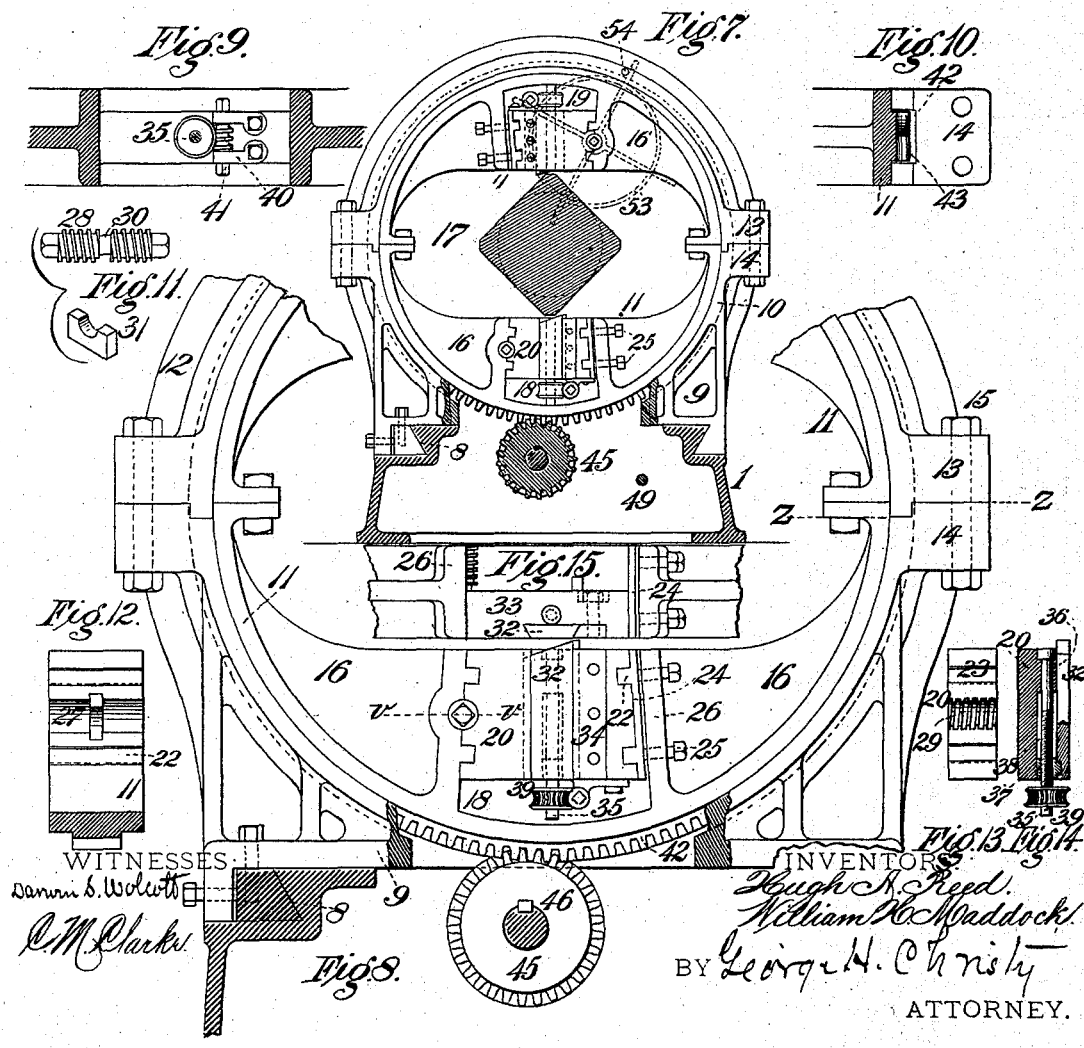
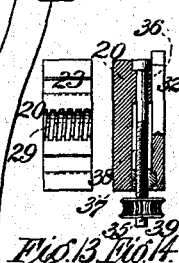
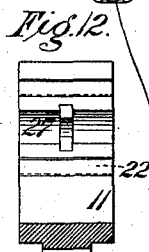
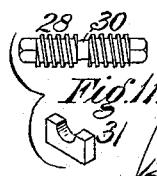
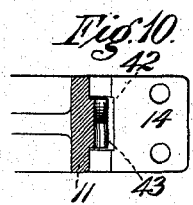
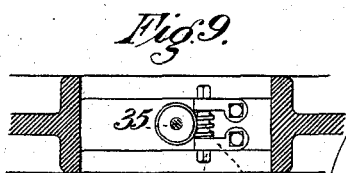
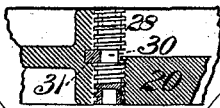
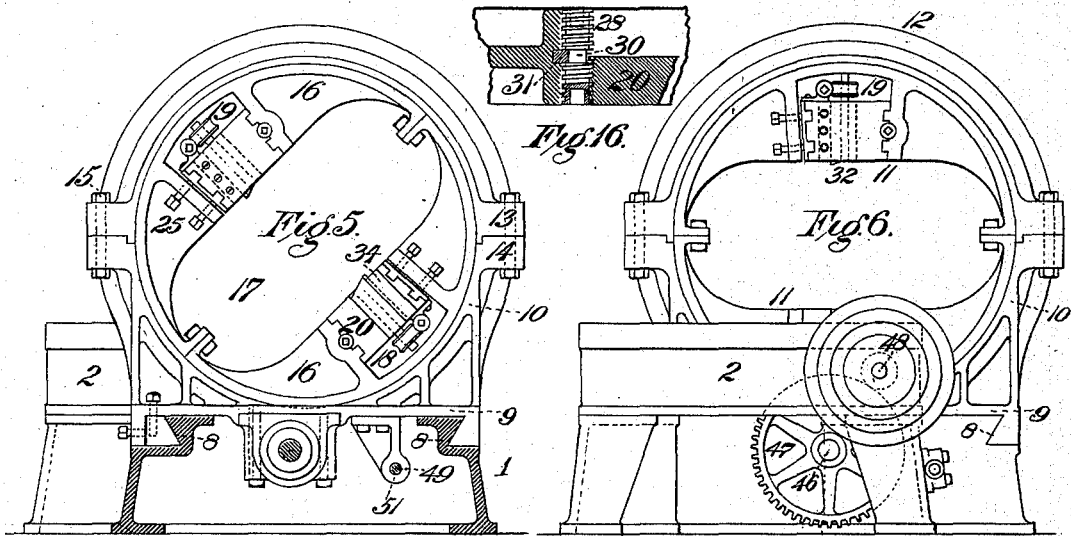

WITNESSES  
Samuel S. Wolcott  
R. M. Clarke

INVENTORS  
Hugh A. Reed,  
William H. Maddock  
BY George H. Christy  
ATTORNEY.

# UNITED STATES PATENT OFFICE.

HUGH A. REED, OF PITTSBURG, AND WILLIAM H. MADDOCK, OF ALLEGHENY, PENNSYLVANIA.

## MACHINE FOR TURNING CRANK-PINS.

SPECIFICATION forming part of Letters Patent No. 322,320, dated July 14, 1885.

Application filed February 24, 1885. (No model.)

*To all whom it may concern:*

Be it known that we, HUGH A. REED, residing at Pittsburg, in the county of Allegheny and State of Pennsylvania, and WILLIAM H. MADDOCK, residing at Allegheny, in the county of Allegheny and State of Pennsylvania, have invented or discovered certain new and useful Improvements in Crank-Pin-Turning Machines, of which improvements the following is a specification.

In the accompanying drawings, which make part of this specification, Figure 1 is a view in side elevation of our improved crank-pin-turning machine. Fig. 2 is a top plan view of the same. Fig. 3 is a transverse sectional elevation, the section being taken on the line *x x*, Fig. 2. Fig. 4 is a detail view on an enlarged scale showing the driving mechanism of the turning-head. Fig. 5 is a transverse sectional elevation on the line *y y*, Fig. 2. Fig. 6 is an end elevation. Fig. 7 is a view similar to Fig. 5, showing the crank-pin in place. Fig. 8 is a view similar to Fig. 7 on an enlarged scale, the upper part of the turning-head being broken away. Fig. 9 is a detail view of the mechanism for feeding in the cutting-tool inwardly. Fig. 10 is a partially-sectional view on line *z z*, Fig. 8, of one of the joints between the half-rings of the turning-head. Fig. 11 is a view showing details of the mechanism for feeding the cutting-tool transversely. Fig. 12 is a detail view showing one wall of the recess for the reception of the tool-carrier. Fig. 13 is a view of one side of the tool-carrier. Fig. 14 is a sectional detail of the mechanism for feeding the tool inwardly. Fig. 15 is a face view of the tool-carrier and that part of the turning-head adjacent thereto. Fig. 16 is a sectional view on line *v v*, Fig. 8, of the tool-carrier and parts adjacent thereto.

Our invention relates to that class of machine-tools which are employed for turning to final shape long lengths of shafting and the crank-pins formed therewith; and the object is to so construct such a machine that both the main portion and crank-pins of engine-shafts may be turned on the same machine, and that perfect parallelism between said main portion and crank-pin may be obtained; and to these ends our invention consists, in gen-

eral terms, in the construction and combination of parts, all as more fully hereinafter described and claimed.

The frame of the machine is formed with a central and two side bed-plates, 1 and 2, the central bed-plate being somewhat lower than the side beds and projects a short distance in front of the same, as clearly shown in Figs. 1 and 2. The inner ends of the side bed-plates project over the central bed toward each other, and in the upper surface of said beds are formed a series of transverse undercut grooves, 4, for the reception of the heads of the clamping-bolts 5, said bolts being adapted to fit in slots or notches in the ends of the clamping-jaws 6 and 7. These clamping-jaws are provided with V-shaped recesses for the reception of the shaft to be turned, which is firmly held in said jaws and to the beds 2 by the bolts 5, as clearly shown in Fig. 3.

In the surface of the bed-plates 2 are cut a series of parallel longitudinal lines or grooves which serve as indices for the adjustment and alignment of the clamping-jaws and the shaft.

On the front and rear edges of the central bed, 1, are formed undercut guideways 8, for the reception of corresponding parts on the carriage 9, supported on said central bed, all as clearly shown in Figs. 7 and 8.

On the carriage 9 is formed a vertical frame or standard, 10, in which is formed a circular seat for the reception of the revolving head 11, said head being held in place by the semi-circular cap-piece 12, having flanges 13 at its extremities adapted to fit and interlock with correspondingly-shaped flanges 14 at the ends of the seat in the standard 10, said flanges being held together by bolts 15.

The revolving head, journaled as above stated in the standard 10, consists of two semicircular parts or half-rings, and in each half-ring is formed a web, 16, partially filling said half-rings and forming, when the latter are placed together in the standard, an oval opening, 17, as clearly shown in several views. In the webs in each half-ring are formed wedge-shaped recesses 18 and 19, in which are placed the tool-carriers 20 and 21. These tool-carriers consist of a wedge-shaped block of metal, steel by preference, provided with transverse slots 22 on two sides, for the reception of cor-

respondingly-shaped tongues 23, formed on one wall of each of the recesses 18 19 in the webs 16, and on a "liner," 24, adjustably attached to the opposite wall of said recesses 5 by bolts 25 passing through lateral flanges 26 of the webs 16.

In that wall of each of the recesses which is provided with the tongues or projections 23, and between said projections, is formed a 10 semicircular transverse groove, 27, (see Fig. 12,) in which is located the threaded shafts 28, and in one side of each tool-carrier, 20 and 21, is formed a similar groove, 29, having in its wall screw-threads adapted to engage with 15 the threads on the groove 27.

In the shaft 28, midway of its length, is formed a groove, 30, adapted to engage the forked key-piece 31, (see Figs. 11 and 12,) said key-piece being held in a notch formed in the 20 groove 27 midway of its length. This key-piece serves to prevent any longitudinal movement of the shafts 28; therefore when the said shafts are rotated by wrenches or other suitable means fitting on their squared ends the 25 tool-carriers which are in engagement with the threads of said shafts through the medium of the threaded grooves 30 are moved transversely in the recesses 18 and 19.

The cutting-tools 32, having one of their 30 edges beveled, as clearly shown, are located in a slot, 33, formed in one side of each cutter-carrier 20 and 21, said slots being made somewhat wider than the body of the tool, and the tools are retained in these slots by locking- 35 plates 34, one edge of said plates being inwardly beveled to bear upon the beveled edges of the tools, as clearly shown in Fig. 15.

The locking-plates are secured in place by 40 bolts passing therethrough and screwing into the block forming the carrier.

The in-and-out adjustment of the tools is effected by the threaded rods 35, said rods having bearings in abutments 36, located at 45 the inner ends of the carriers, and having the nuts 37, mounted on their threaded portions, said nuts being arranged in slots 38, in the carrier in the rear of the tools, and being provided with nibs or lugs adapted to fit into 50 openings in the under side of the tools, near their rear ends. (See Fig. 14.)

On the outer ends of the rods 35 are secured the worm-wheels 39, arranged to mesh with the screw 40, formed on the rod 41, said rod 55 being mounted in bearings secured on the outer ends of the carrier-blocks, as shown. The outer ends of these rods 41 are made square or any other irregular shape in cross-section for the reception of a wrench or other device for turning the rods.

Around the periphery of the semicircular 50 rings composing the revolving head 11 are V-shaped or angular teeth 42, said teeth projecting into a groove, 43, formed on the inner surface of the standard 10 and cap-piece 12 55 by the rims 44, which serve as a seat or bearing-surface for the revolving head. The teeth 42 on the revolving head intermesh with the

correspondingly-shaped teeth on the pinion 45, said pinion being secured to the counter-shaft 46, as against rotation thereon, by a spline and 70 groove, said groove being made of sufficient length to permit the pinion 45 being slid along said shaft an amount equal to the movement of the carriage 9 on the central bed, 1. The counter-shaft 46 is mounted in suitable bearings 75 depending from the under side of the bed 1, and is provided at one end with the gear-wheel 47, which intermeshes with the pinion on the power-shaft 48, mounted in suitable bearings in one of the side beds, 2. 80

In the central bed, 1, near its front side, is mounted the shaft 49, on which is formed the threads 50, which engage a nut, 51, secured to or formed in an arm extending from the under side of the carriage 9. This shaft 49 can 85 be rotated by hand to effect the movement of the carriage through the medium of the hand-wheel 52; or it may be rotated by power in any convenient and well-known manner.

The two semicircular rings composing the 90 revolving head are secured together by bolts passing through lugs 52, projecting inwardly from the ends of such semicircular rings. By forming the teeth on the revolving head and its driving-pinion V-shaped or angular, a 95 steadiness and uniformity of motion is obtained in the revolving head unattainable in the usual construction of teeth—*i. e.*, parallel with the axis of the pinion and revolving head.

In using the above-described machine, the 100 revolving head is rotated until the points of junction between its half-rings are in line with the point of junction between the cap-plate and the standard 10. The cap-plate and upper half-ring are removed. The shaft is then 105 placed on the bed 2 with that portion of the shaft which is to be operated on lying within that portion of the revolving head which has been left in position in the standard 10. The shaft is then adjusted by sliding the clamping- 110 jaws across the beds 2, the operator being aided in making such adjustment by the index lines running longitudinally of the beds, one of said lines being cut so as to lie in a vertical plane passing through the center of rota- 115 tion of the revolving head. After the shaft has been properly adjusted the upper clamping-jaws are put in place, and the upper and lower clamping-jaws are clamped to the shaft and the beds 2. The upper half-ring of the re- 120 volving head and the cap-plate are then replaced and secured. As soon as the shaft has been adjusted in position and the parts of the machine replaced and secured, as above stated, the carriage 9 is moved to one end of its bed 125 and the tool-carriers are adjusted to the same side of the revolving head. The cutters are then adjusted inward sufficiently far to effect the desired amount of cut, the rear tool being adjusted a little farther in than the front tool. 130 The adjustment is effected by placing a wrench on the squared end of the rod 41 and rotating said shaft and the screw formed thereon. This screw in turn rotates the feed-screw 35, there-

by effecting the inward movement of the tool. The revolving head is then rotated through the medium of the pinion 45 and its connections with the power-shaft. As the head is rotated the carriage is gradually moved along its bed by means of the threaded shaft 49 and nut 51, the shaft being rotated by the hand-wheel 52 on the shaft 49, or by any suitable automatic mechanism applied to said shaft.

As soon as the carriage has reached the opposite end of its bed the carriage-feeding mechanism is stopped, and during the further rotation of the head the tool-carriers are fed in the same direction as the previous motion of the carriage, such feed of the tool-carriers being effected by the rotation of the threaded shafts 28. Although these shafts can, if desired, be rotated by hand, suitable wrenches being placed on their squared ends, it is preferred that such rotation be effected automatically, a star-wheel, 53, being placed upon one end of each shaft 28, said wheel being adapted to engage a pin, 54, secured to the standard 10 in such relation to the path of the star-wheel that one of the arms thereof will engage such pin once during the rotation of the head, and thereby effect the desired rotation of the shafts 28, and the consequent movement of the tool-carriers.

In some instances—as, for example, in the case of small shafts—the straight portions of such shafts may be turned in any suitable lathe and the shaft be then transferred to the above-described machine for turning the crank-pin; but in the case of large shafts the entire finishing or turning operation can be performed on our machine; and as the index

lines are made parallel with the movement of the carriage, parallelism of all parts of the shaft can be secured.

We claim herein as our invention—

1. In a machine for turning crank and other shafts, a central bed having mounted thereon a reciprocating tool-carriage, in combination with two side beds having their upper surfaces raised above the upper surface of the central bed, substantially as set forth.

2. In a machine for turning crank-shafts, a central bed having mounted thereon a reciprocating carriage, in combination with two shaft-supporting beds, arranged at the sides of the central bed, projecting in front of the side beds, substantially as set forth.

3. A revolving-head, in combination with tool-carrier, mounted therein and automatically adjustable transversely of the head, and a vertically-adjustable cutter mounted in a recess in the tool-carrier, substantially as set forth.

4. In a machine for turning crank and other shafts, two beds arranged to support the shaft on each side of the portion to be operated on, and provided with index lines or marks along their faces, in combination with clamp-blocks having V-shaped jaws and adapted to be secured to the shaft and to the supporting-beds, substantially as set forth.

In testimony whereof we have hereunto set our hands.

HUGH A. REED.

WILLIAM H. MADDOCK.

Witnesses:

DARWIN S. WOLCOTT,

R. H. WHITTLESEY.